



CLEMCO

The Performance System

TECHNICAL DATA SHEET

Note: For safe, efficient blasting, read and follow the owner's manual and seek training for everyone who will use this equipment.

Purpose

The CMS monitor detects carbon monoxide and hydrocarbons in a compressed air supply and triggers visual and audible alarms when CO is detected in concentrations of 10 parts per million. CMS-1 is wall-mountable; CMS-2 is field-portable with integral rugged carrying case.

NOTE: CMS monitors do not remove CO or convert CO to CO₂.

Requirements for Operation

- Compressed-air source (55 to 145 psi) of Grade D breathing air as defined by the Compressed Gas Association commodity specification: G-7.1 (www.cganet.net).
- Air flow of 0.5 to 0.8 scfh at 55 psi or more to operate and maintain adequate sampling
- Power – 120 volt AC or 12 volt DC. Line cord provided for 120 volt AC; may be conduit wired.

Description of Operation

Connect the CMS to the air supply and to an electric power source. The system warms up and stabilizes in about five minutes.

Once stabilized, the unit is operational and continuously monitors the incoming air. The indicator light glows green to indicate adequate air pressure and flow, and that the CO concentration is below 10 ppm. The alarm light glows yellow, and a loud, intermittent alarms sounds if air flow or pressure drops.

The air-quality light turns red and the CMS sounds a loud, constant alarm if CO reaches 10 ppm. To prevent CO poisoning, the operators must immediately remove their respirators and exit the blast environment.

Once the source of CO has been located, and corrected, the CMS will continue to monitor the air and will glow green automatically when the CO has passed out of the air supply.

Description

Carbon monoxide monitor and alarm for breathing air supplied from a compressed air source. Features warning lights, high-decibel audible alarm, particulate/oil filter, and connections for optional remote alarm and shutdown devices. Unit monitors air supply; can serve multiple respirators.



Model CMS-2 Field-Portable

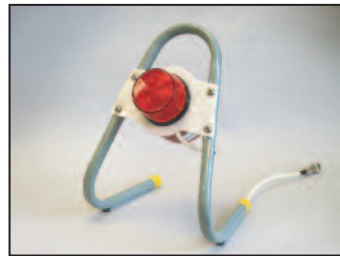

CMS Remote Alarm

CMS Series Carbon Monoxide Alarms

**Model CMS-1 Wall-Mountable, with Calibration Kit:
Stock No. 23017**

**Model CMS-2 Field-Portable, with Calibration Kit:
Stock No. 22894**



Model CMS-1 Wall-Mountable

Advantages

- One monitor can serve multiple respirators
- Microprocessor circuit and digital readout provide accurate readings
- Simple, rugged construction for in-plant or field use
- Manual calibration accomplished in minutes
- Long-lasting replaceable sensor
- May be used with 120 volt AC or 12 volt DC power source
- Accommodates optional remote alarm kit

Approvals and Certifications

- Meets OSHA requirement for CO monitoring

Specifications

- Shielded to reject radio frequency interference
- Includes 10 feet of 1/8-inch tubing and connector fittings
- Electrochemical sensor responds instantly to CO
- CMS-1 has polycarbonate case with impact-resistant clear plastic cover meets NEMA-4 specifications
- CMS-2 has polyethylene case with dual hinges, dual latches, and dust-tight, weather-resistant rubber seal
- Nominal noise rating of 98 dB at distance of one foot for the standard alarm; and 100 dB at distance of 3.1 feet for the optional remote alarm.

Options and Accessories

HumidifierStock No. 03600

Remote alarm kit includes: remote alarm, stand, wiring connector, and 50-ft. cord.....Stock No. 22909

Remote alarm extension cordStock No. 22910

Related Clemco Literature

Description

	Stock No.
Operator Safety Equipment	07764
CMS-1 Owners Manual	23301
CMS-2 Owners Manual	22925

Replacement Parts

Item Description

	Stock No.
(-) CMS-1 CO monitor package, includes: monitor, calibration connector, and 10 PPM test gas	23017
1. CMS-1 CO monitor includes: monitor and items 3 to 9	23012
2. Calibration connector assembly	23011
3. Test gas 10 PPM	22865
Test gas, impurity free	11132
4. Regulator /Filter	23013
5. Flowmeter	21376
6. Horn w/ wire, 12 Volt DC	22922
7. Adaptor, straight, 1/8" NPT x 1/8" barb	11732
8. Adaptor, elbow, 1/8" NPT x 1/8" barb	11733
9. Tubing, urethane, per foot	12475
10. Reducer, 1/4" x 1/8"	02026
(-) Sensor (not shown)	23015
(-) Filter element (not shown)	23014

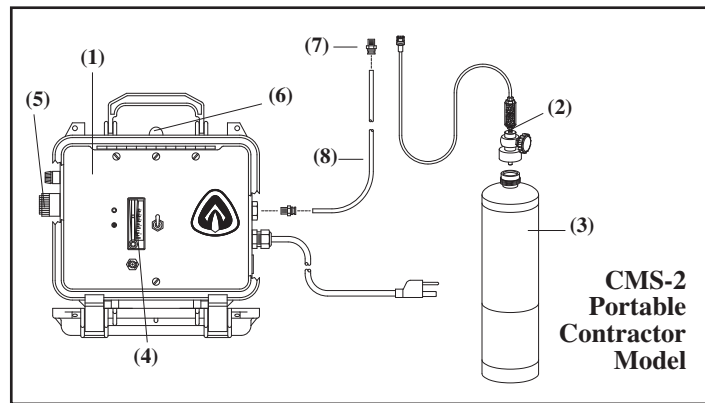
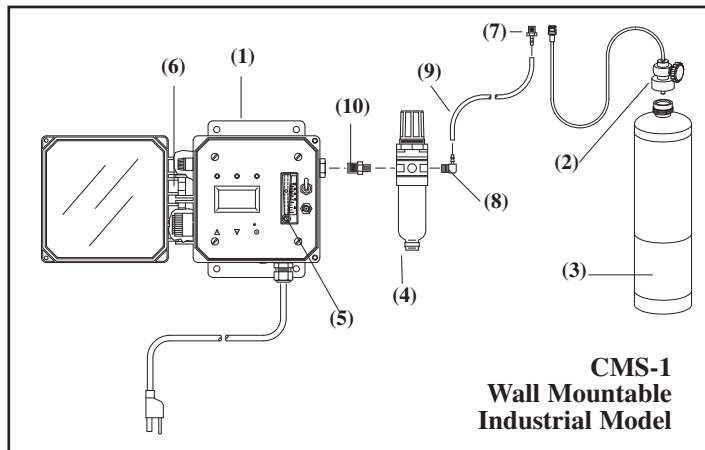

Color: CMS-2: black case w/ white graphic front
 CMS-1: gray metal enclosure w/ white graphic front
 Optional Remote Alarm: gray metal

Item Description

Stock No.

(-) CMS-2 CO monitor/alarm package, includes: monitor, calibration connector, and 10 PPM test gas.	
120 V AC	22894
12 V DC	25024
1. CMS-2 CO monitor/alarm (instrument only)	22892
120 V AC	22892
12 V DC	25072
220 V AC	25532
2. Calibration connector assembly	22893
3. Test gas 10 PPM	22865
Test gas, impurity free	11132
4. Flowmeter	21376
5. Horn w/ wire, 12 Volt DC	22922
6. Alarm light, exterior w/ wire	22923
7. Fitting, 1/4" OD, quick fit	22924
8. Tubing, urethane, per foot	12475
(-) Sensor (not shown)	22919
(-) Regulator/filter (not shown)	22920
(-) Filter element (not shown)	22921
(-) Air-line humidifier	03600

Optional Remote Alarm

(-) Remote Alarm: includes: alarm, stand, wiring connector and 50 ft. cord	22909
1. Cable, remote alarm extension 50 feet	22910
2. Strobe light	22984
3. Horn	22985
4. Wiring adaptor	22986
5. Stand assembly with internal wiring	22987

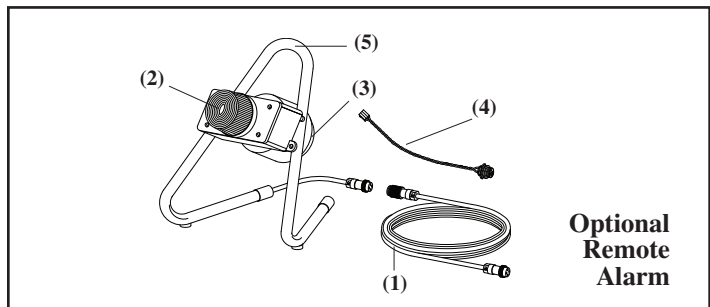

Packaging: Ships in one carton with owner's manual.

Stock No. Dimensions Shipping Wt.

23017	7-1/2" H x 7 1/2" W x 5-1/2" D	8 lb
23012	7-1/2" H x 7 1/2" W x 5-1/2" D	6 lb
22894	9-1/4" H x 10 3/8" W x 5" D	9 lb
22892	9-1/4" H x 10 3/8" W x 5" D	7 lb

Authorized Distributor:

ISO 9001:2008 certified. Clemco is committed to continuous product improvement. Specifications are subject to change without notice.

© 2012 Clemco Industries Corp. • One Cable Car Drive • Washington, MO 63090 • Phone (636) 239-4300 • Fax (800) 726-7559

Stock No. 23248

www.clemcoindustries.com

0901 Rev. C, 11/12